

EN **Operating instructions**
Retain for future reference.

EN Translation from the original German version.

All other documents in different languages are translations of the original version.

All rights reserved in the event case of patent, utility model or design registrations.

Contents

1	Introduction	4
2	Safety instructions	5
3	System description	9
4	Technical data	11
5	Preparation	16
6	Operation	21
7	Maintenance	25
8	Decommissioning and disposal ...	26
9	Certification and Legal Disclosure	27

1 Introduction

This user manual describes the functions and features of the ExitSafe system. ExitSafe enables accumulator battery buffered operation for electrically powered roller shutters and venetian blinds.



Follow the instructions in these manuals to ensure proper and safe use.

Retain for future use.

1.1 Manufacturer contact details

elero GmbH

Maybachstr. 30

73278 Schlierbach

Telephone: +49 (0)7021 9539-0

Email: info@elero.de

Website: www.elero.de

1.2 Symbols and warnings

This user manual uses the following illustrations to display important warnings:

DANGER



Danger with a high level of risk, resulting in death or serious injury.

WARNING



Danger with a medium level of risk, possibly resulting in death or serious injury.

CAUTION



Danger with a low level of risk, possibly resulting in minor injuries.

NOTICE



Danger, possibly resulting in damage to property.

2 Safety instructions

2.1 Target group

This document is primarily intended for use by electricians, technicians and engineers with experience in the design, installation, commissioning and maintenance of building technology.

2.2 Intended use

ExitSafe was developed for the operation of electrically powered roller shutters and venetian blinds. The ExitSafe system is designed for the operation of 12 V DC tubular motors on a 230 V AC network with temporary failure of the mains supply and occasional use.

ExitSafe allows for the creation of a 2nd escape route with electric powered roller shutters and venetian blinds.

WARNING



Injuries / material damage may occur as a result of improper use!



ExitSafe may not be used in escape routes and primary rescue routes in accordance with the Model Building Regulation (MBO).

WARNING

- Do not use in locations where failure or malfunction could result in the obstruction of an escape route or a primary rescue route.
- If you are unsure whether ExitSafe is suitable for your specific application, please consult the manufacturer or your supplier.

When using ExitSafe, compliance with the national and international safety and accident prevention regulations specific to the application is required.

ExitSafe components are designed for installation in flush-mounted or surface installation boxes. Any conversions or other modifications to ExitSafe are not permitted.

2.3 Transport

WARNING



Risk of fire due to short circuiting or thermal runaway of the battery pack as a result of damage or improper handling of the ExitSafe.

- Use the packaging enclosed.
- Handle the components of the ExitSafe carefully.
- Avoid transporting fully charged battery packs.
- Observe the permitted storage temperature.
- Avoid impacts, blows or drops.

2.4 Installation and commissioning

WARNING



Risk of injury due to unexpected start-up of the connected drive.

- Disconnect the ExitSafe battery pack before performing work on the drive.
- Only perform work on the electrical connection if it has been disconnected from the power supply.

WARNING



Risk of injury, damage to the ExitSafe and damage to the area surrounding the ExitSafe as a result of improper electrical connections.

- The electrical connection may only be conducted by qualified personnel.
- Only perform work on the electrical connection if it has been disconnected from the power supply.
- Observe the charge level of the battery pack.
- Note the technical data for the device.
- Take care to ensure proper and firmly fixed connections.

NOTICE



Exchanging components of the ExitSafe with third party components may damage the components or other connected systems.

NOTICE

- Exchange components between different systems only after consultation with the manufacturer or your supplier.
- When replacing a component, check whether the type description of the new component matches the one being replaced.

2.5 Repairs

Damaged ExitSafe components may only be repaired by the manufacturer. If necessary, contact your supplier.

2.6 Warranty

- The warranty period for ExitSafe is 12 months from the date of purchase. Damages caused due to improper use are excluded.
- Never open the device without authorisation. Opening the housing renders the warranty null and void.
- No warranty claims may be made for damage caused to the ExitSafe due to improper operation resulting from non-observance of the operating instructions or due to a disregard of these instructions.
- There is no liability for consequential damages.

3 System description

3.1 Application area

ExitSafe enables mains-buffered operation for electrically powered roller shutters, venetian blinds and rolling doors. ExitSafe may be used if the function of one tubular motor has not yet been enabled, even in the event of a failure in the 230 V mains supply of a building.

3.2 General overview of functions

The ExitSafe receives the commands UP and DOWN/CLOSE from a local operator position (individual control) or from the building automation (master control) via potential-free contacts at the inputs. ExitSafe controls the connected DC drive with the corresponding sense of rotation accordingly. The drive is powered by the ExitSafe battery pack. The battery pack is then slowly recharged via the mains supply.

The ExitSafe monitors the charging status of the battery pack. If the charging status has fallen to the point that only one complete UP movement of the drive can be guaranteed, then a warning signal will sound. For this case, the ExitSafe can be set to allow automatic control of the drive.

The performance of the ExitSafe battery pack decreases over time. For this reason, the battery pack should be replaced after two years or 500 charging cycles. A warning signal can be set in ExitSafe to sound when that this time period has been reached.

3.3 System design

ExitSafe consists of two main components:

- Control module (ExitSafe-S)
- Battery pack (ExitSafe-A)

Figure 1 (next page) displays the connection of the ExitSafe schematically.

3.3.1 Control module (ExitSafe-S)

The ExitSafe-S control module connects the motor, mains supply, battery pack and all required command initiators. The control module also contains the switches for setting the ExitSafe. The control module evaluates these switches and the connected command initiators and controls the motor accordingly. It supplies the motor with power from the battery pack. The control module generates voltage via the mains connection, which is used to recharge the battery pack.

3.3.2 Battery pack (ExitSafe-A)

The battery pack ExitSafe-A stores the power required to operate the ExitSafe. The battery pack contains various protective devices that prevent damage to the battery cells due to overvoltage or undervoltage, short circuits or overloading.

Terminal connection diagram

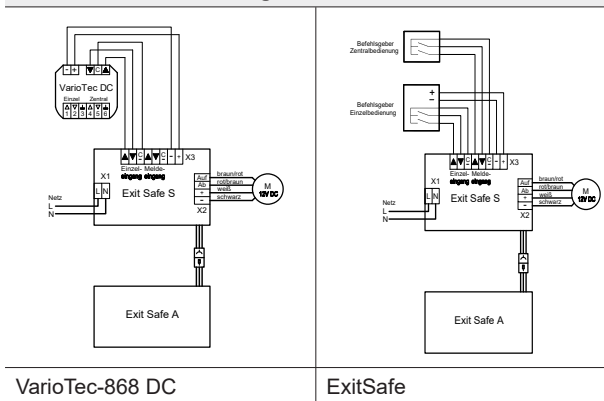

Figure 1: Schematic connection diagram

4 Technical data

4.1 Type plate

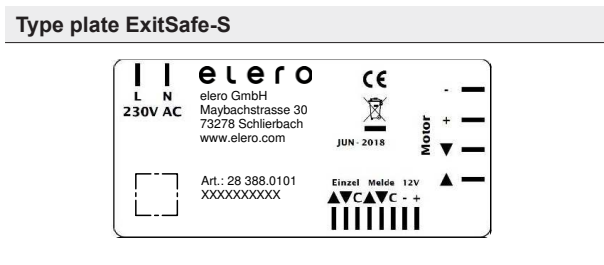

Figure 2: Control module type plate

Type plate ExitSafe-A



Figure 3: Control module battery pack

4.2 Electrical data

Electrical data	
Power supply input	230 V AC/50 Hz
Max. power consumption for input	5.5 W
Output voltage motor terminals	8.4 ... 12 V DC
Rated current motor terminals	4 A
Max. current motor terminals	22 A, 10 ms
Rated current command initiator	1.2 mA
Output voltage supply control elements	8.4 ... 12 V DC
Rated current supply control elements	50 mA
Battery type	Li-Ion, 18650, 3S1P
Rated voltage battery pack	10.8 V
Nominal capacity of the battery pack	3400 mAh
Recommended charging voltage	12 V DC
Recommended charge current	700 mA

Electrical data

Max. control factor	1200 s / 8 h
Maintained mode period	180 s
Software class	A

4.3 Ambient conditions

Ambient conditions

Protection class	IP 20
Operating temperature	0° ... +60 °C
Storage temperature	20° ... +60 °C
Relative air humidity	0 ... 95%
Max. altitude	2000 m over NHN

4.4 Mechanical data

Mechanical data

Control module (ExitSafe-S) dimensions	67x40x22 mm
Control module (ExitSafe-S) weight	60 g
Battery pack (ExitSafe-A) dimensions	70x55x20 mm
Battery pack (ExitSafe-A) weight	168 g

4.5 Electrical connections

The ExitSafe is supplied with power via the spring clamp (X1) on the control module with 230 V AC.

Designation	Assignment
L	External conductor
N	Neutral conductor



Table 1: Assignment power input

The control and supply of the motor to be connected via the screw contacts (X2) on the ExitSafe control module.

No.	Designation	Assignment
1	-	0 V Motor Supply
2	+	+ 8.4 ... 12 V DC motor supply
3	down	Signal DOWN/ CLOSE for motor
4	up	Signal UP for motor

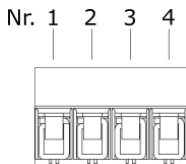
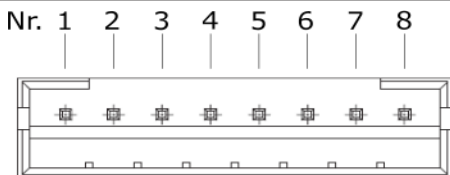

Table 2: Assignment motor terminals

The ExitSafe is controlled by potential-free contact command initiators. These are connected to the connector strip (X3) on the control module. Control elements that need to be supplied even in the event of a failure in the mains supply can also be connected to this connector strip.

Control elements



No.	wire color	Designation	Assignment
1	green	Individual ▲	Signal UP from individual control
2	yellow	Individual ▼	Signal DOWN/CLOSE from individual control
3	grey	Individual C	Common dimensions for individual inputs
4	violet	Signal ▲	Signal UP from master control or sensor
5	brown	Signal ▼	Signal DOWN/CLOSE from master control
6	blue	Signal C	Common dimensions for signal inputs
7	black	-	0 V supply control elements
8	red	+	+ 8.4 ... 12 V DC supply control elements



Table 3: Assignment control elements

Insulate unused wires against contact.

Do not connect the control cables to the circuit board until the wiring has been completed.

5 Preparation

5.1 Product contents

Designation	Fig.
<p>ExitSafe Article-No. 283880001 Complete unit shown in installation double-box (not included)</p>	 A photograph of an orange plastic installation double-box. Inside the box, a black battery pack is mounted on a printed circuit board (PCB). Several wires are connected to the PCB and extend out of the box.
<p>Control module ExitSafe-S</p>	 A photograph of a blue printed circuit board (PCB) control module. It features a black relay component and a white label with the text "ERB 00028-ET18". A multi-colored ribbon cable is connected to the top of the module.
<p>Battery pack ExitSafe-A Article-No. 283881201 (replacement)</p>	 A photograph of a black rectangular battery pack. It has a white label with technical specifications and the text "ExitSafe" and "REPLAZI". A multi-colored ribbon cable is connected to one end of the battery pack.



Designation	Fig.
Connection cable for control elements Article-No. 221470001	
User manual Article-No. 181234601	Retain for future use.

Table 4: Product contents

5.2 Optional accessories

Designation	Fig.
Extension 2,2 m for JA drives (4 wires with QuickOn plug) Article-No. 221470001 Important: Use a maximum of 1 extension per drive.	

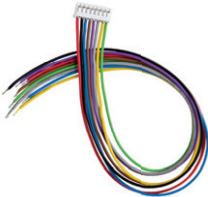
5.3 Packing

The packaging has been designed to protect the ExitSafe during transport by freight carrier or parcel delivery service. After unpacking, please check all delivered components for completeness or damage.

The packaging must be disposed of separately in accordance with the applicable rules for cardboard and plastic.

5.4 Settings

The ExitSafe-S control module has six DIP switches to set the functions listed in Table 5. These settings should be configured before installing the ExitSafe.

DIP switches

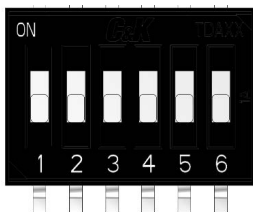

Default setting:
All 6 DIP switches
in the OFF position.

DIP switch No.	Function position OFF	Function position ON
1	Individual control has priority over master control	Master control has priority over individual control
2	After 2 years of operation or 500 charging cycles of the battery pack, a warning signal will sound.	No warning signal will sound after 2 years of operation or 500 charging cycles of the battery pack.
3	When the battery pack is low, the motor will not be controlled automatically.	When the battery pack is low, the motor will be controlled automatically.
4	Push-button mode	Maintained mode operation.

DIP switch No.	Function position OFF	Function position ON
5	Maintained mode is active immediately.	Maintained mode is active after a delay.
6	Normally open contact at the input signal ▲.	Normally closed contact at input signal ▼ (wire breakage recognition).

Table 5: Settings overview

5.5 Connection and installation

WARNING



Risk of injury, damage to the ExitSafe and damage to the area surrounding the ExitSafe due to improper electrical connections.

- The electrical connection may only be conducted by qualified personnel.
- Only perform work on the electrical connection if it has been disconnected from the power supply.
- Observe the charge status of the battery pack.
- Note the technical data for the device.
- Do not extend connecting cable of the shutter drive.
- Take care to ensure proper and firmly fixed connections.

ExitSafe must be installed in a dust-free and dry environment.

Recommended procedure for installing and connecting the ExitSafe into an installation double-box [e.g. from Kaiser GmbH (www.kaiser-elektro.de) installation box in-wall ECON 1068-21 resp. hollow wall 9062-94]:

1. First check whether the ExitSafe components can be inserted into the installation space without connecting the cables. Depending on the design of the installation box, a different sequence may be appropriate. Please note that the battery pack should be replaced after 2 years.
2. Connect the required command initiators and control elements to the eight-pin connection cable that has not yet been plugged in. Any open ends of lines that are not being used are to be insulated.
3. Connect the motor with original connection cable to the four-pole screw terminal of the control module. The sense of rotation of the motor can be adjusted by exchanging the cables at the terminals up and down.
4. Connect the mains supply to the two spring clamps on the control module.
5. Insert the eight-pin connection cable to the control module.
6. Insert the battery pack and the control module into the installation box. Pay attention to the cable routing and avoid putting pressure on the components.
7. Connect the battery pack to the control module using the plug connection.

5.6 Commissioning

The battery pack is delivered in power-saving mode with a low charge level to prevent it from giving off any energy initially. ExitSafe is not ready for operation in this state. In order to be fully operational, the battery pack must first be charged.

Procedure for commissioning the ExitSafe:

1. First carry out the installation steps described in Chapter 5.4 Connection and assembly.
2. Switch on the ExitSafe power supply. After a few minutes, the battery pack starts to charge via the control module.
3. Wait eight hours.
4. Check the sense of rotation of the drive.
5. Check all connected command initiators and control elements.
6. Check all required functions when the mains supply is switched off.

6 Operation

6.1 Individual and master control

ExitSafe is controlled via the inputs Individual ▲, Individual ▼, Sensor ▲ and Sensor ▼. These inputs must be controlled using command initiators with potential-free contacts. The motor connected to the ExitSafe is controlled based on these inputs.

The function of the inputs can be adjusted via the DIP switches as described below.

6.1.1 Priority individual or master control

Switch 1 OFF

In this position, the inputs *Individual* ▲ and *Individual* ▼ have priority over the inputs *Signal* ▲ and *Signal* ▼ in case of simultaneous operation.

Switch 1 ON

In this position, the inputs *Sensor ▲* and *Sensor ▼* have priority over the inputs *Individual ▲* and *Individual ▼* in case of simultaneous operation.

6.1.2 Push-button mode or maintained mode

ExitSafe can be operated either in push-button mode or with maintained mode. The duration of the maintained mode is approx. 180 s and can be terminated earlier via a short input pulse.

Switch 4 OFF

Push-button mode. The motor is only activated as long as an input is operated. This is helpful if a connected command initiator takes over the maintained mode.

Switch 4 ON & switch 5 OFF

Immediate maintained mode. Motor control remains active after the input signal has dropped.

Switch 4 ON & switch 5 ON

Delayed maintained mode. During short operation, the motor is only activated briefly. Only after it is operated for a longer period, does the activation of the motor remain active after the input signal drops. This is helpful for adjusting venetian blind slats during short operations.

6.1.3 Wire breakage recognition

This function is only available for the input *Signal ▲*. All other inputs are designed for normally open contacts.

Switch 6 OFF

No wire breakage recognition. The command initiator at the input Signal ▲ is a normally open contact.

Switch 6 ON

Wire breakage recognition The command initiator at the input Signal ▲ is a normally closed contact.

6.2 Signalling

The ExitSafe control module emits the following audible warnings:



Warning signal	Meaning and measures
<p>1 x long</p>  <p>The signal sounds with every actuation</p>	<p>Replacement of the battery pack required. 2 years of operation or 500 charging cycles of the battery pack have been reached.</p> <ul style="list-style-type: none">• Change the battery pack.
<p>2 x short</p>  <p>The signal sounds once and with every actuation.</p>	<p>Low charge status. The charge status of the battery pack required for reliable functionality has not been reached.</p> <ul style="list-style-type: none">• Avoid further actuation of the drive.• If necessary, restore the mains supply.

Table 6: Warning signals

DIP switch 2 can be used to set the warning signal for replacing the battery pack. The warning signal for a low battery level cannot be disabled.

Switch 2 OFF

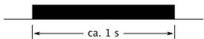
The signal for replacing the battery pack sounds.

Switch 2 ON

The warning signal for replacing the battery pack is deactivated. An acoustic signal is only emitted in the case of a low battery pack charge level.

6.3 Automatic start-up

When automatic start-up is activated, ExitSafe activates the motor when the charge status of the battery pack has dropped to such an extent that only one complete movement of the motor can be guaranteed.

Automatic start-up can be set using DIP switch 3.

Switch 3 OFF

No automatic start-up. An acoustic signal is emitted only in the case of a low battery pack charge level.

Switch 3 ON

Automatic start-up activated. When the battery pack is low, a warning signal sounds and the drive is controlled.

6.4 Shutdown and restart

Note the following points when switching off the power supply over a longer period of time:

- If automatic start-up is activated, the motor will be automatically triggered after some time without the mains supply. To avoid this, disconnect the battery pack.

- The battery pack will enter power saving mode after several days without being recharged. ExitSafe is not ready for operation in this state.
- In order to be fully operational after the mains supply has been switched on again, the battery pack must first be charged for several hours.

6.5 Additional information

- Charging cycles and operating times are recorded by the battery pack itself. For this reason, after replacing the battery pack, no further steps are necessary to set up the control module for the new battery pack.
- The power supply source for the motor is always the battery pack. For this reason, operation of the motor from the control module is not possible without a battery pack.

7 Maintenance

7.1 Cleaning

The components of the ExitSafe do not require any special cleaning, as long as they are protected inside an installation box against contamination.

7.2 Maintenance

The performance of the ExitSafe battery pack after prolonged use or frequent unloading. For this reason, it should be replaced after two years.

If DIP switch 2 on the control module is set to OFF, a warning signal will sound after 2 years of operation or 500 charging cycles of the battery pack. The battery pack should then be replaced promptly.

The battery pack to be replaced should be depleted before being replaced by repeatedly actuating the drive.

Charging cycles and operating times are recorded by the battery pack itself. For this reason, after replacing the battery pack, no further steps are necessary to set up the control module for the new battery pack.

7.3 Repairs

Damaged ExitSafe components may only be repaired by the manufacturer. If necessary, contact your supplier.

8 Decommissioning and disposal

8.1 Disassembly

WARNING



Risk of injury and damage due to unconnected electrical cables.

- The electrical connection may only be modified by qualified personnel.
- Only perform work on the electrical connection if it has been disconnected from the power supply.
- Observe the charge status of the battery pack.
- Ensure that any connecting cables that have been removed are not left unprotected (insulate).

If you would like to convert ExitSafe components, please proceed as follows:

1. Switch off the power supply.
2. Deplete the battery pack by actuating the drive repeatedly.
3. Disconnect the battery pack from the control module.

4. If the components have been installed in an installation box, remove them.
5. Disconnect all connected cables.

8.2 Disposal

Battery packs are to be disposed of in accordance with the legal regulations for (rechargeable) batteries. Please cover any open contact points before disposal.

The control module must be disposed of in accordance with the legal regulations for electronic devices.

The packaging must be disposed of separately in accordance with the applicable rules for cardboard and plastic.

9 Certification and Legal Disclosure

9.1 EC Declaration for Conformity

elero hereby declares that ExitSafe is in compliance with Directive 2014/53/EU. The full text of the EU Declaration of Conformity is available at the following Internet address: www.elero.com/downloads-service/downloads

9.2 Legal Disclosure

elero GmbH
Maybachstr. 30
73278 Schlierbach
GERMANY

Telephone: +49 (0)7021 9539-0

Email: info@elero.de

Website: www.elero.de

WEEE-Reg.-No. DE 26410414

© elero GmbH 2019

All rights reserved. All copyrighted names and trademarks mentioned (such as product names, logos, business names) are protected for the respective right owners.